

CORNER DRIVE EG
04019
Functions

Element for transmission of movement of the hardware on the crane side to the upper and/or lower cross beam.

Finish

Base finish

Packaging

Box of 10 pieces

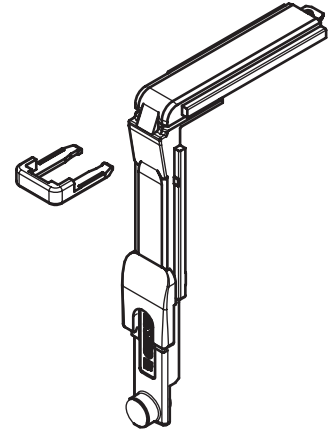
Technical Features

Left/right reversible and equipped with a fixed pawl for creating a lock point in combination with the adjustable striker, on the crane side or cross beam side, depending on how the drive is to be positioned.

It is secured using a hooking clip enabling quick and easy fixing without having to machine the profile and without screws. It snaps on and is removed using a screwdriver.

Materials

Zamak body and hand

Zamak clip

